

- "H" DIMENSION REPRESENTS DISTANCE FROM TOP OF FINISH DOWN TO POINT WHERE LINE TANGENT TO "T" INTERSECTS TOP OF BEAD. WHERE BEAD DIAMETER AND CONSTRUCTION IS AT OR NEAR SPECIFIED "T" DIAMETER, THE PLUS TOLERANCE IS NOT REQUIRED. WHEN FINISH IS MADE WITHOUT BEAD, "H" DIMENSION IS MEASURED TO SHOULDER AND ITS PLUS TOLERANCE IS INCREASED BY .40 ON SIZES UP TO AND INCLUDING 28 AND BY .65 ON SIZES LARGER THAN 28.
- B = HELIX ANGLE OF FIXTURE TO CUTTER.
- TANGENT $B = \frac{\text{PITCH}}{\pi (\text{MEAN BETWEEN MEAN 'T' AND MEAN 'E'})}$
- A MINIMUM OF ONE TURN OF THREAD SHOULD BE MAINTAINED WITH FULL PROJECTION EXCEPT WHEN DEPRESSED OR INTERRUPTED AT MOLD SEAMS. REFER TO GLASS FINISH NO. 405 FOR DEPRESSED THREAD DETAIL.
- CONTOUR OF BEAD OR TRANSFER RING TO BE OPTIONAL PROVIDED TOP OF BEAD CLEARS 5°.
- "I" DIMENSION IS MEASURED THROUGH FULL LENGTH OF FINISH.
- FOR ENGLISH DIMENSIONS PLEASE REFER TO GPI DRAWING FOR 400 FINISHES.
- MANY CHILD RESISTANT CLOSURES RELY ON DISSIMILAR SIMULTANEOUS MOTIONS FOR THEIR PROPER FUNCTION. THE GPI 400 FINISH DOES NOT NECESSARILY PROVIDE PHYSICAL SPACE FOR THESE MOTIONS. ANY USER SHOULD OBTAIN SPECIFICATIONS FROM THE SPECIFIC CLOSURE MANUFACTURER.
- FOR ALL SPECIAL APPLICATIONS, THE END USER SHOULD OBTAIN SPECIFICATIONS FROM THE SPECIFIC CLOSURE MANUFACTURER.

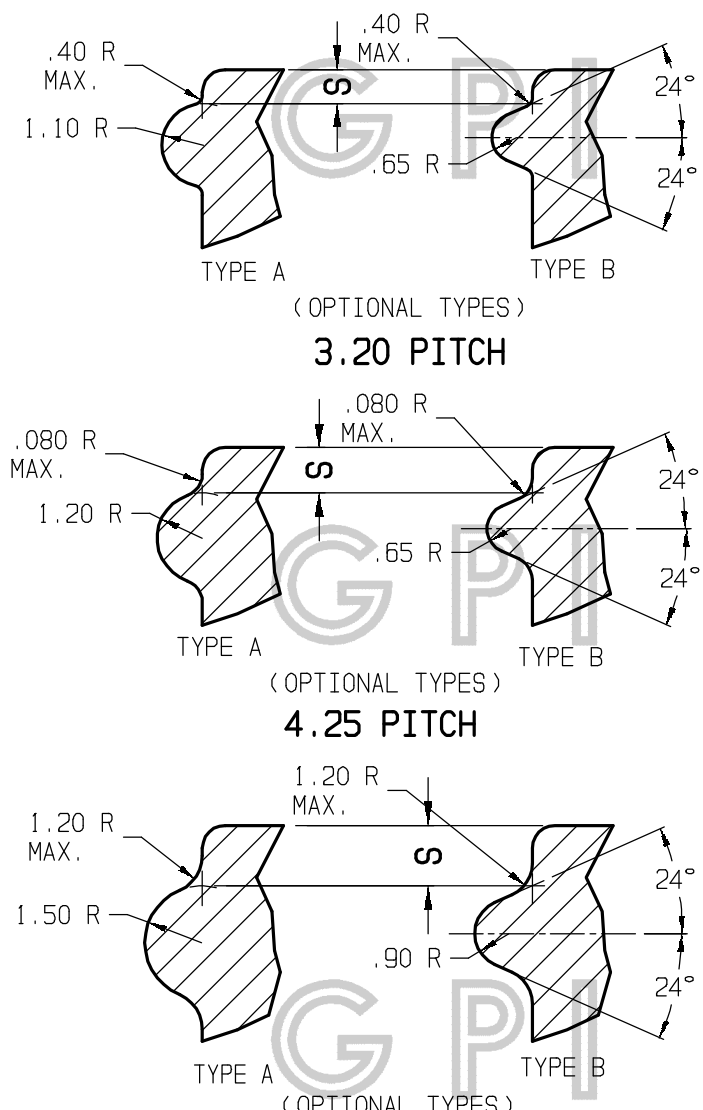

**5.10 PITCH
THREAD CROSS
SECTIONS**

SIZE	T	E	H	I	R	S	B	CUT DIA.	PITCH
			SEE NOTE 1	MIN.	MAX.				
18	17.65 ±.25	15.50 ±.25	9.05 ±.20	8.3	1.1	0.9 ±.3	3° 31'	9.5	3.20
20	19.65 ±.25	17.50 ±.25	9.05 ±.20	10.3	1.1	0.9 ±.3	3° 8'	9.5	3.20
22	21.65 ±.25	19.50 ±.25	9.05 ±.20	12.3	1.1	0.9 ±.3	2° 50'	9.5	3.20
24	23.60 ±.25	21.50 ±.25	9.80 ±.20	13.1	1.1	1.2 ±.4	2° 35'	9.5	3.20
28	27.30 ±.35	24.90 ±.35	9.80 ±.20	16.3	1.6	1.2 ±.4	2° 58'	12.7	4.25
30	28.30 ±.35	25.90 ±.35	9.85 ±.25	16.6	1.6	1.2 ±.4	2° 51'	12.7	4.25
33	31.80 ±.35	29.40 ±.35	9.85 ±.25	20.1	2.0	1.2 ±.4	2° 32'	12.7	4.25
35	34.20 ±.45	31.85 ±.45	9.85 ±.25	22.2	2.0	1.2 ±.4	2° 21'	12.7	4.25
38	37.05 ±.45	34.65 ±.45	9.85 ±.25	25.1	2.0	1.2 ±.4	2° 10'	12.7	4.25
40	39.70 ±.45	37.30 ±.45	9.85 ±.25	27.7	2.0	1.2 ±.4	2° 1'	12.7	4.25
43	41.60 ±.45	39.20 ±.45	9.85 ±.25	29.6	2.0	1.2 ±.4	1° 55'	12.7	4.25
45	43.75 ±.45	41.35 ±.45	9.85 ±.25	31.8	2.0	1.2 ±.4	1° 49'	12.7	4.25
48	47.05 ±.45	44.65 ±.45	9.85 ±.25	35.1	2.0	1.2 ±.4	1° 41'	12.7	4.25
51	49.55 ±.45	47.15 ±.45	10.00 ±.40	37.6	2.0	1.2 ±.4	1° 36'	12.7	4.25
53	52.05 ±.45	49.65 ±.45	10.00 ±.40	40.1	2.0	1.2 ±.4	1° 31'	12.7	4.25
58	56.05 ±.45	53.65 ±.45	10.00 ±.40	44.1	2.0	1.2 ±.4	1° 25'	12.7	4.25
60	59.00 ±.50	56.60 ±.50	10.00 ±.40	47.1	2.0	1.2 ±.4	1° 20'	12.7	4.25
63	62.00 ±.50	59.60 ±.50	10.00 ±.40	50.1	2.0	1.2 ±.4	1° 12'	12.7	4.25
66	65.00 ±.50	62.60 ±.50	10.00 ±.40	53.1	2.0	1.2 ±.4	1° 13'	12.7	4.25
70	69.00 ±.50	66.60 ±.50	10.00 ±.40	57.1	2.0	1.2 ±.4	1° 9'	12.7	4.25
75	73.50 ±.50	71.10 ±.50	10.00 ±.40	61.6	2.0	1.2 ±.4	1° 4'	12.7	4.25
77	76.60 ±.50	74.20 ±.50	12.00 ±.40	64.7	2.0	1.6 ±.4	1° 2'	12.7	4.25
83	82.50 ±.50	79.45 ±.50	12.00 ±.40	69.9	2.0	1.6 ±.4	1° 9'	12.7	5.10
89	88.65 ±.55	85.60 ±.55	13.20 ±.40	74.1	2.0	1.6 ±.4	1° 4'	12.7	5.10
100	99.45 ±.55	96.40 ±.55	14.80 ±.40	84.9	2.0	1.6 ±.4	0° 57'	12.7	5.10
110	109.40 ±.60	106.35 ±.60	14.80 ±.40	94.9	2.0	1.6 ±.4	0° 53'	12.7	5.10
120	119.35 ±.65	116.30 ±.65	17.00 ±.40	104.9	2.0	1.6 ±.4	0° 47'	12.7	5.10

THIS OFFICIAL GLASS PACKAGING INSTITUTE PRINT CONSTITUTES ONE IN A SERIES OF VOLUNTARY STANDARDS INTENDED TO PROVIDE A BASIS FOR ACHIEVING COMPATIBILITY AND INTERCHANGEABILITY BETWEEN MANUFACTURERS AND USERS OF GLASS CONTAINERS AND CLOSURES THEREFOR. THE USER SHOULD BE AWARE THAT OTHER CONTAINER AND CLOSURE DESIGNS MAY DIFFER FROM THIS VOLUNTARY STANDARD, AND IT IS THE USER'S RESPONSIBILITY TO MAKE THE FINAL DETERMINATION AS TO DESIGN AND COMPATIBILITY. GPI ASSUMES NO RESPONSIBILITY FOR EITHER THE USE OF OR INTERPRETATION OF THE STANDARD, FOR IT BEING CURRENT, OR FOR THE DETERMINATION WHETHER ANY PARTICULAR MANUFACTURER'S PRODUCT CONFORMS TO THE STANDARD. THIS DRAWING CONTAINS INFORMATION TAKEN FROM ONE OR MORE PRINTS OF THE GLASS PACKAGING INSTITUTE (GPI). GPI OWNS ALL RIGHT, TITLE AND INTEREST IN THE COPYRIGHTS TO THIS DRAWING AND TO THESE PRINTS. GPI REQUIRES THAT YOU NOT REPRODUCE THIS DRAWING FOR OR DISTRIBUTE THIS DRAWING TO ANY THIRD PARTY WITHOUT GPI'S WRITTEN CONSENT. ANY INQUIRIES OR SUGGESTIONS CONCERNING THIS STANDARD CAN BE ADDRESSED TO THE GLASS PACKAGING INSTITUTE, WASHINGTON D.C. AT WWW.GPI.ORG.

COPYRIGHT © GPI 1995, 1999, 2001

Edward Grant CHAIRMAN	PRINTED AND DISTRIBUTED AS A VOLUNTARY STANDARD BY GLASS PACKAGING INSTITUTE COMMITTEE ON DESIGN AND SPECIFICATIONS	APPROVED FOR PUBLICATION 6-21-01	SUPERSEDES DWG. NO. FM-4006
GLASS FINISH NUMBER 400M		GPI DWG. NO.	
METRIC CONTINUOUS THREAD FINISH		FM-4007	