

GPI-1680 ROLL-ON FINISH COMPATIBLE WITH STEL® CAPSULES



TECHNICAL BULLETIN

(see drawing on page 4)

This bulletin is to inform you of the revision to the standard GPI-1680 glass finish specification. This revision as outlined below allows the glass container manufacturers to work to and provide their customer base one standard finish construction for both Liquor and Wine end use containers.

The Design and Specifications Committee of the Glass Packaging Institute have consulted a major capsule supplier for their input and agreement on the following revisions.

In Figure 1 are photos of aluminum capsules for Liquor (BVP finish) and Wine (BVS finish) containers. The differences between these systems are found in the liner type, application of the capsules, and dimensional specifications.

The Liquor capsule is applied with a top seal pressure block, whereas the Wine capsule is applied with a top and side seal pressure block. Note the side seal at the top of the Wine capsule. Upon application of the Wine capsule, the top and side seal pressure block redraws the aluminum capsule elongating it approximately .020" [0.5 mm]. Due to this elongation during application, the Wine finish "L" dimension on the container's mold neck is also increased .020" [.51 mm].



FIGURE 1

**GPI-1680 GLASS FINISH
FOR STEL TYPE CAPSULES
TECHNICAL BULLETIN**
Page 2

The "S" and "H" dimensions for the Wine finish (BVS) have also been increased .045" [1.15 mm] and .041" [1.05 mm] respectively to allow the pressure block to form the side seal without interfering with the thread start and also maintaining sufficient thread travel and engagement. See Figure 2.

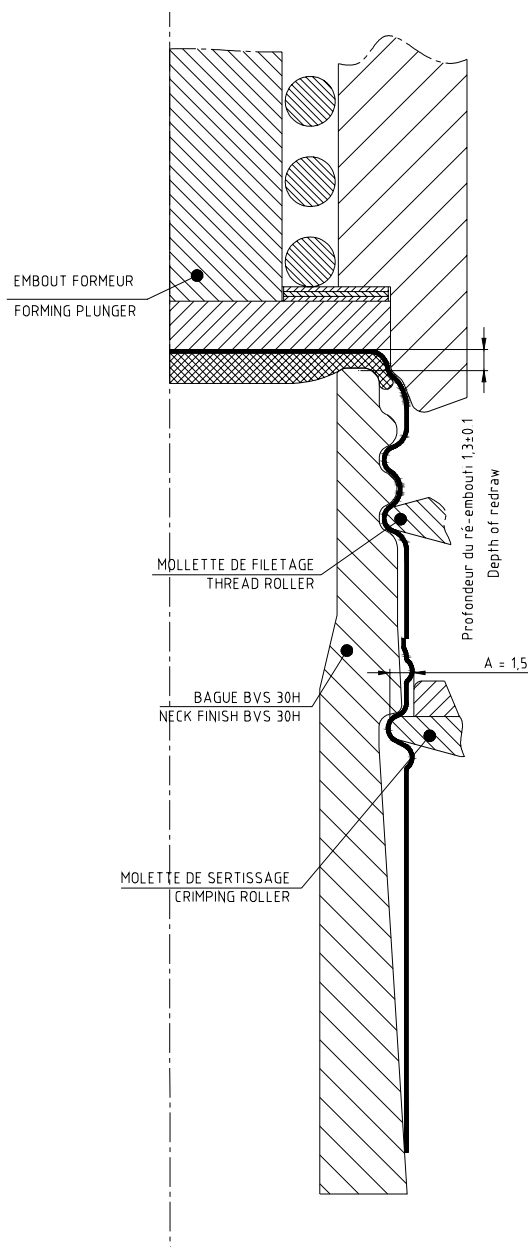

FIGURE 2



**GPI-1680 GLASS FINISH
FOR STEL TYPE CAPSULES
TECHNICAL BULLETIN**

Page 3

These major revisions are on the attached GPI-1680 drawing, 1680-03, dated 06/15/2005 and are as follows:

"S" dimension revised to .110" [2.79mm] from .065" [1.65mm] on sizes 30 mm diameter and above.

"H" dimension revised to .409" [10.39mm] from .368" [9.35mm] on sizes 30 mm diameter and above.

"L" dimension increased .020" [.51mm] on sizes 30 mm diameter and above, along with neck angle controls at the "K" diameter.

Current users of the GPI-1680 finish will need to work with their glass container and closure suppliers to transition into the revised finish. The closure manufacturer working with the Design and Specification Committee has advised that both the top seal pressure block and the top and side seal pressure block can be utilized for this revised finish.

For Wine end use the top and side seal pressure block is necessary and is the only new part that is required on the capping head. Current capping head thread rollers will need to be adjusted .045" [1.15 mm] for the proper location on the revised finish. For Wine containers, the vertical load pressure on the top of the closure is 360 lbf ± 40 lbf on the 30mm and 31.5mm sizes.

For Liquor end use the top seal pressure block will not need to be replaced but the current capping head thread rollers will need to be adjusted .045" [1.15 mm] for the proper location on the revised finish. For Liquor containers, the vertical load pressure on the top of the closure is 270 lbf ± 40 lbf on the 30mm and 31.5mm sizes.

We ask that you contact your glass container and closure manufacturers for planning the transition of the revised GPI-1680 Finish, and also for any further questions you may have in regards to this transition.

Best regards,

Design & Specifications Committee of
The Glass Packaging Institute.

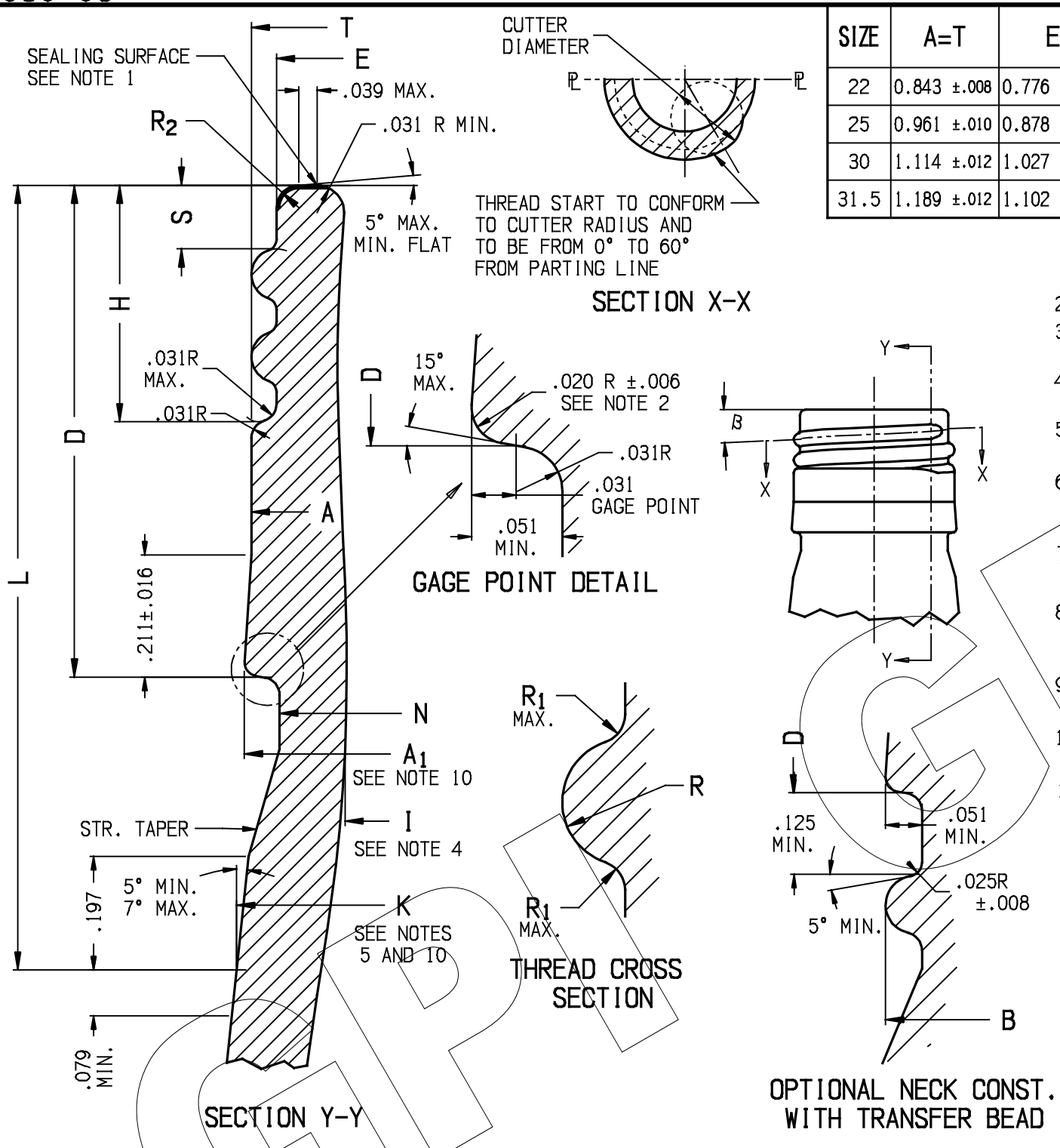

SIZE	A=T	E	A ₁ SEE NOTE 10	S	H	D	N MAX.	B MAX.	I MIN.	R	R ₁ MAX.	R ₂	B	CUT. DIA.	T.P.I.
22	0.843 ±.008	0.776 ±.008	0.860 ±.010 (±.006)	0.065 ±.010	0.287 ±.008	0.658 ±.008			0.483	0.034	0.016	0.031 ±.012	2° 15'	0.375	10
25	0.961 ±.010	0.878 ±.010	0.980 ±.010 (±.006)	0.065 ±.010	0.327 ±.010	0.658 ±.010			0.590	0.042	0.020	0.031 ±.012	2° 29'	0.375	8
30	1.114 ±.012	1.027 ±.012	1.138 ±.012 (±.008)	0.110 ±.010	0.409 ±.010	0.851 ±.010	1.024	1.138	0.680	0.044	0.025	0.039 ±.012	2° 26'	0.500	7
31.5	1.189 ±.012	1.102 ±.012	1.209 ±.012 (±.008)	0.110 ±.010	0.409 ±.010	0.851 ±.010	1.094	1.209	0.680	0.044	0.025	0.039 ±.012	2° 16'	0.500	7

- SEALING SURFACE MUST BE SEAMLESS TOP, FLAT PREFERRED, SMOOTH AS POSSIBLE, AND MUST NOT DIP DOWN INSIDE OF THE FINISH. A 5° MAX. UPWARD ANGLE MAY BE USED TO ENSURE SEALING SURFACE DOES NOT DIP DOWN INSIDE OF FINISH. 5° MAX. ANGLE INCREASES 'H', 'D', AND 'L' DIMENSIONS BY A MAXIMUM OF .004.
- RADIUS TO BE AS SHARP AS POSSIBLE.
- 'H' DIMENSION REPRESENTS DISTANCE FROM TOP OF SEALING SURFACE DOWN TO THE HORIZONTAL LINE TANGENT TO THE BOTTOM SWING OF THE .031 MAX. RADIUS AND IS REQUIRED FOR MOLD MAKERS GUIDANCE.
- MIN. 'I' DIMENSION IS FOR FILL TUBE CLEARANCE AND EXTENDS THROUGH ENTIRE LENGTH OF THE FINISH AND NECK OF BOTTLE.
- A SLIGHTLY UNDER MIN. 'K' DIMENSION IS ACCEPTABLE, HOWEVER THE MINIMUM MUST BE MAINTAINED FOR AT LEAST HALF THE CIRCUMFERENCE. THE MAXIMUM SPECIFICATION CANNOT BE EXCEEDED.
- SATISFACTORY THREADING REQUIRES A MINIMUM OF 360° OF FULL DEPTH AND WIDTH OF ROOT OF THREAD FOR THE R.O. CAP. BEYOND THAT POINT THE ROOT OF THE THREAD SHOULD BE INCREASED GRADUALLY TO FULL THREAD DIAMETER 'T' IN 180° OF TURN.
- TANGENT B = $\frac{\text{PITCH}}{\pi (\text{MEAN BETWEEN MEAN 'T' AND MEAN 'E'})}$
- IT IS PERMISSIBLE TO RELIEVE THE THREAD AND THE 'A₁' DIAMETER OF THE BEAD AT THE MOLD SEAM, NOT TO EXCEED .008 ON DIAMETER IN AN ARC OF 30 DEGREES. THE 'T' AND 'A₁' DIMENSIONS ARE NOT MEASURED IN THE DEPRESSED AREAS.
- THIS FINISH IS NOT INTENDED TO BE USED FOR CONTENTS UNDER PRESSURE. FOR SUCH APPLICATIONS IT IS THE RESPONSIBILITY OF THE GLASS PURCHASER TO CONSULT WITH ITS CLOSURE AND CONTAINER SUPPLIERS.
- THE MAIN TOLERANCE GIVES THE ABSOLUTE OVALITY LIMIT FOR 'A₁' AND 'K'. THE AVERAGE OVALITY OF THE VALUE IN () IS TO BE MAINTAINED AND IS CALCULATED AS FOLLOWS: AVERAGE OVALITY = (MAX. + MIN.) / 2 - IDEAL.
- THIS STANDARD FINISH CONSTRUCTION IS FOR BOTH LIQUOR AND WINE END USE.

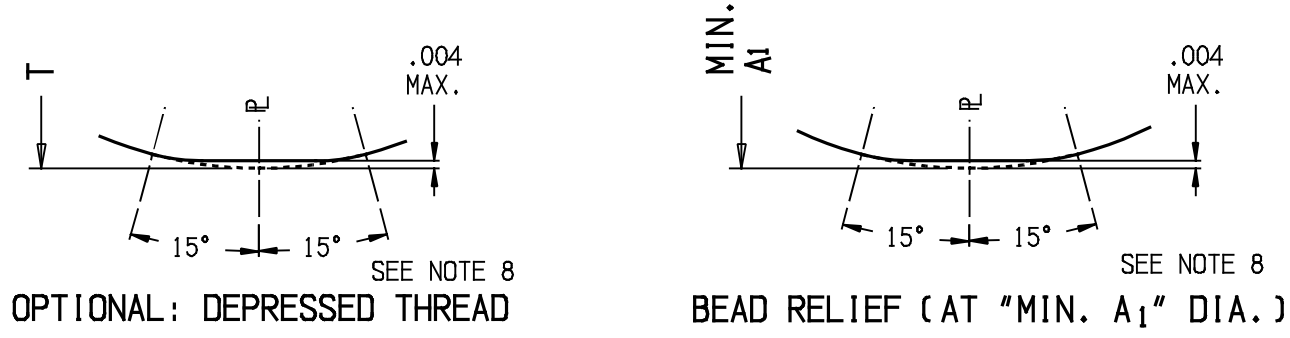

OPTIONAL NECK CONST. WITH TRANSFER BEAD

SIZE	L											K SEE NOTE 10
	30	33	35	43	40	44	50	55	60	65	70	
22	1.142											0.878 ±.020 (±.008)
25		1.260		1.654								0.996 ±.020 (±.008)
30			1.358			1.713	1.949	2.146	2.343	2.540	2.736	1.165 ±.028 (±.016)
31.5					1.555	1.713	1.949	2.146	2.343			1.232 ±.028 (±.016)

THIS OFFICIAL GLASS PACKAGING INSTITUTE PRINT CONSTITUTES ONE IN A SERIES OF VOLUNTARY STANDARDS INTENDED TO PROVIDE A BASIS FOR ACHIEVING COMPATIBILITY AND INTERCHANGEABILITY BETWEEN MANUFACTURERS AND USERS OF GLASS CONTAINERS AND CLOSURES THEREFOR. THE USER SHOULD BE AWARE THAT OTHER CONTAINER AND CLOSURE DESIGNS MAY DIFFER FROM THIS VOLUNTARY STANDARD, AND IT IS THE USER'S RESPONSIBILITY TO MAKE THE FINAL DETERMINATION AS TO DESIGN AND COMPATIBILITY. GPI ASSUMES NO RESPONSIBILITY FOR EITHER THE USE OF OR INTERPRETATION OF THE STANDARD, FOR IT BEING CURRENT, OR FOR THE DETERMINATION WHETHER ANY PARTICULAR MANUFACTURER'S PRODUCT CONFORMS TO THE STANDARD. THIS DRAWING CONTAINS INFORMATION TAKEN FROM ONE OR MORE PRINTS OF THE GLASS PACKAGING INSTITUTE (GPI). GPI OWNS ALL RIGHT, TITLE AND INTEREST IN THE COPYRIGHTS TO THIS DRAWING AND TO THESE PRINTS. GPI REQUIRES THAT YOU NOT REPRODUCE THIS DRAWING FOR OR DISTRIBUTE THIS DRAWING TO ANY THIRD PARTY WITHOUT GPI'S WRITTEN CONSENT. ANY INQUIRIES OR SUGGESTIONS CONCERNING THIS STANDARD CAN BE ADDRESSED TO: GLASS PACKAGING INSTITUTE, WASHINGTON D.C. AT WWW.GPI.ORG.

COPYRIGHT © GPI 1996, 1999, 2001, 2005

Edward A. Grant CHAIRMAN	PRINTED AND DISTRIBUTED AS A VOLUNTARY STANDARD BY GLASS PACKAGING INSTITUTE COMMITTEE ON DESIGN AND SPECIFICATIONS	APPROVED FOR PUBLICATION 6-15-05	SUPERSEDES DWG. NO. 16802
	Karl Reisig SECRETARY	GLASS FINISH NUMBER 1680	GPI DWG. NO. 1680-03

ROLL-ON FINISH COMPATIBLE WITH STEL® CAPSULES